

# MR Passenger Elevator

## Hoistway Structure

Concrete  Brick & Concrete  Other

Unstandard  Standard

Compact type

NOTE

Technical Requirement:

HW	HOISTWAY WIDTH	CW	CAR INSIDE WIDTH	Type	TKJ1000 / 1.0 -VF		
HD	HOISTWAY DEPTH	CD	CAR INSIDE DEPTH	F/P/D	/ /	Door type	Side open
OP	DOOR OPENING WIDTH	CH	CAR HEIGHT	load	1000 kg	speed	1.0 m/s
ROP	WALL OPENING WIDTH	MRW	MACHINE ROOM WIDTH	Machine	MCK200	Roping	2:1
OPH	DOOR OPENING HEIGHT	MRD	MACHINE ROOM DEPTH	T/sheave	φ 4.00	D/sheave	φ 4.00
OH	OVERHEAD HEIGHT	MRH	MACHINE ROOM HEIGHT	car sheave	φ 4.00	CW sheave	φ 4.00
CAR DBG	DISTANCE BETWEEN CAR GUIDE RAILS			Shaft	HW 1750 mm x HD 2600 mm		
CWT DBG	DISTANCE BETWEEN COUNTERWEIGHT GUIDE RAILS			Cabin	CW 1100 mm x CD 2100 mm		
				Door	OP 900 mm x OPH 2100 mm		

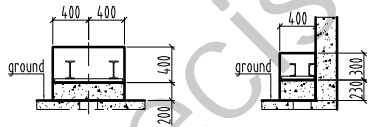

A, reserved hole/1:60 C, reserved hole/1:60

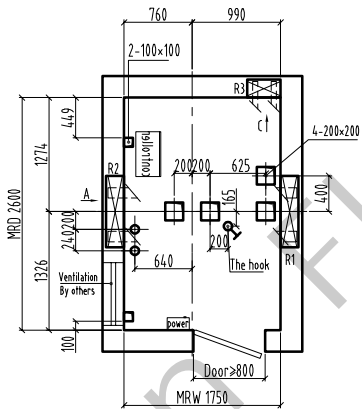

Machine room plan/1:60

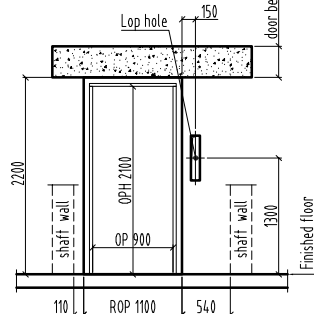

E/ reserved hole/1: 60

Bottom box Lop: 100x500 (base station) 100x400 (remaining stations)  
No bottom box Lop hole: φ50 hole

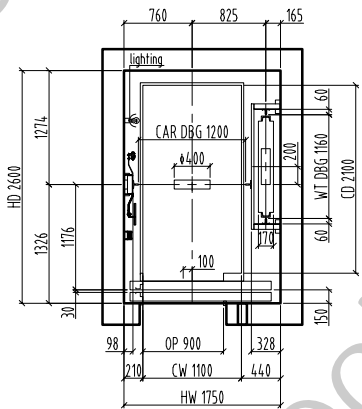

Hoistway plan/1:60

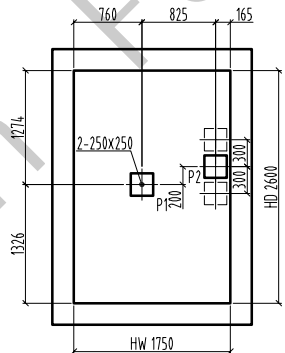

Pit plan/1: 60

When  $v < 1.0\text{m/s}$ ,  $H = 300$ ; when  $1.0\text{m/s} < v < 1.75\text{m/s}$ ,  $H = 800$ ; when the lifting height is more than 35m, the buffer pier P2 is arranged according to the dotted line, the bearing capacity is pressed A single P2/2 calculation.

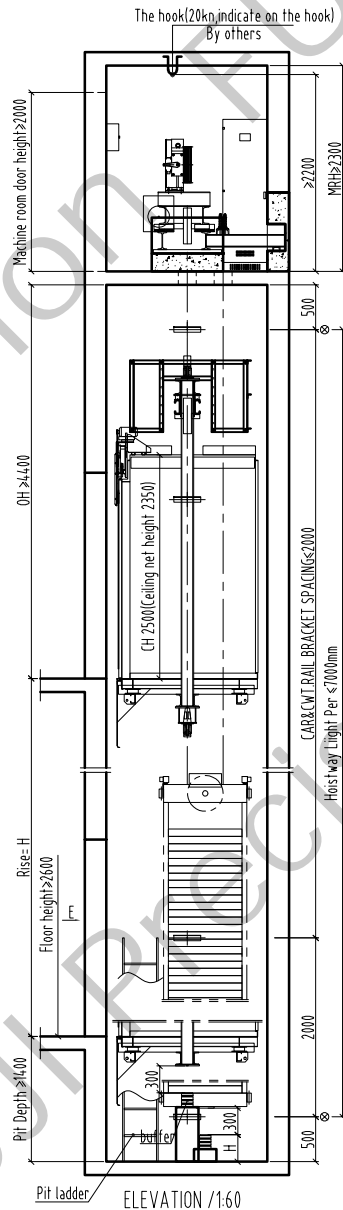

The hook(20kn indicate on the hook) By others

OH	>=4.400
Rise	H
26 F	
25 F	
24 F	
23 F	
22 F	
21 F	
20 F	
19 F	
18 F	
17 F	
16 F	
15 F	
14 F	
13 F	
12 F	
11 F	
10 F	
9 F	
8 F	
7 F	
6 F	
5 F	
4 F	
3 F	
2 F	
1 F	
G F	
B F	
Pit	>=1400
Floor	Height

Drawing	FTK1000-05-	approver	
Drawing No.	FTK1000-05-		
manufacturing no.			
Project name			

FUJI PRECISION